

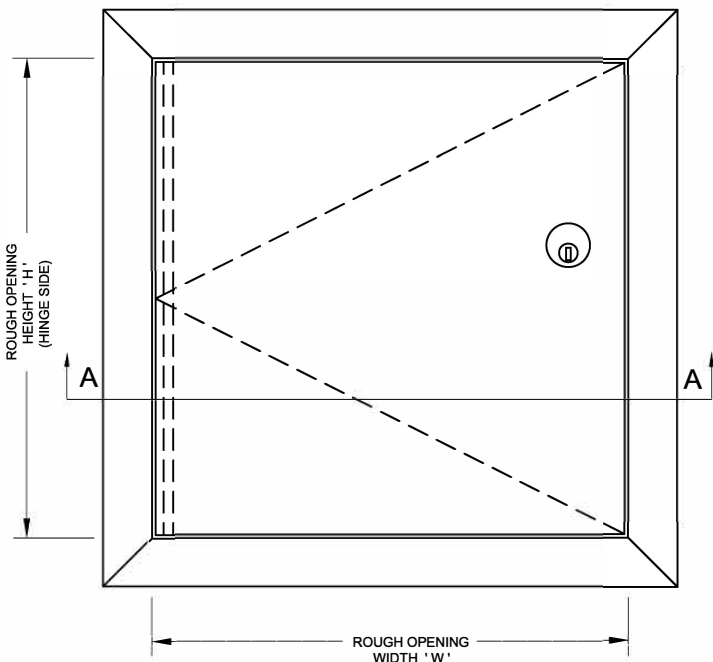

5 7978 North Fraser Way
Burnaby, B.C. V5J 0C7
Tel: 604 433 4243
Fax: 604 433 4148
E-mail: info@maxammetal.com

VAN-MET[®] MODEL FSD
TWO HOUR FIRE-RATED ACCESS DOOR
Uninsulated Security Door for Wall Application

Designed for use where both fire rating and security are required.



FRONT ELEVATION

STANDARD CONSTRUCTION:

- MATERIAL** - SATIN FINISH GALVANIZED (GALVANNEALED) STEEL.
- PANEL** - 2.75mm [12 ga].
- FRAME** - 2.75mm [12 ga].
- FLANGE** - EXTERIOR FLANGE WIDTH 32mm [1¼"].
- HINGE** - CONCEALED CONTINUOUS ROD HINGE.
- PANEL CLOSER** - THE AUTOMATIC PANEL CLOSER WILL CLOSE AND LATCH THE DOOR FROM AN OPEN POSITION OF APPROXIMATELY 90° AS REQUIRED BY CODE.
- LOCK** - 1⅝" MORTISE PREP COMPLETE WITH MORTISE CYLINDER.
- FINISH** - RUST INHIBITIVE PRIME COAT (OFF-WHITE).

* Specifications subject to change without notice.

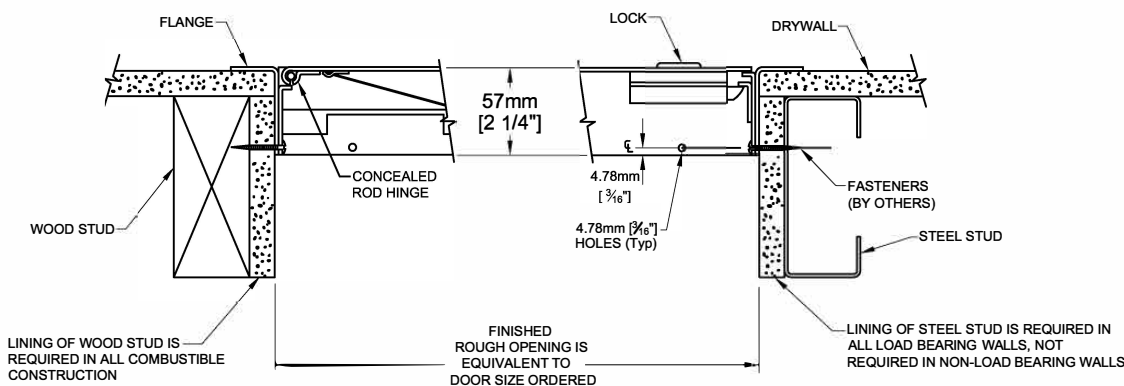

SECTION A-A

PROJECT: _____

CONTRACTOR: _____

ARCH. OR ENG.: _____

DATE: _____

Revised 26/07/22

These drawings are the property of Maxam Metal Products Ltd. and incorporates information which is proprietary. Publication and/or public distribution in whole or in part is expressly prohibited without the prior written consent of Maxam Metal Products Ltd. The information herein remains the property of Maxam Metal Products Ltd. All rights reserved.

DWN BY KB	DATE Oct / 2023	DWG. NO. Sheet 1 of 3	REV. 1
--------------	--------------------	--------------------------	-----------



5 7978 North Fraser Way
 Burnaby, B.C. V5J 0C7
 Tel: 604 433 4243
 Fax: 604 433 4148
 E-mail: info@maxammetal.com

VAN-MET[®] MODEL FSD
TWO HOUR FIRE-RATED ACCESS DOOR
Uninsulated Security Door for Wall Application

INSTALLATION:

The frame is manufactured with mounting holes. Factory installed anchor straps are available for masonry, upon request. See installation instructions supplied with panel.

WARRANTY:

One Year Limited warranty. For complete details see **Access Door** warranty document.

ORDERING:

- PLEASE ORDER BY ROUGH OPENING SIZE.
- WHEN ORDERING THE SECOND DIMENSION GIVEN IS THE HINGE SIDE. (ie. 457mm x 610mm [18" x 24"], THE 610mm [24"] DIMENSION IS THE HINGE SIDE.
- **THESE DOORS ARE NON-RETURNABLE**

FSD - STANDARD SIZES

Rough Opening Size W x H		No. of Locks	Weight in kgs.	Weight in lbs.
Metric (mm)	Inches			
203 x 203	8 x 8	1	2.61	5.76
305 x 305	12 x 12	1	5.90	13.00
406 x 406	16 x 16	1	10.43	23.00
457 x 457	18 x 18	1	13.23	29.16
457 x 610	18 x 24	1	17.64	38.88
457 x 762	18 x 30	1	22.04	48.60
559 x 762	22 x 30	1	26.94	59.40
610 x 610	24 x 24	1	23.51	51.84



Net Opening = Width minus 64mm [2½"]
 Height minus 51mm [2"]

PROJECT SCHEDULE

- millimeters
- inches

Qty	Rough Opening Size		Options
	Width	Height	



Model FSD is designed to maintain the continuity of a fire barrier when installed in a **vertical separation**. The assembly is manufactured under the factory inspection service of Intertek (Warnock Hersey) and has a label reading: "Listed access frame and fire door assembly. **2 hour fire rating**. Vertical installation only. No temperature rise rating."

PROJECT: _____
 CONTRACTOR: _____
 ARCH. OR ENG.: _____
 DATE: _____

PURCHASE ORDER: _____
 APPROVED BY: _____

Revised 26/07/22

DWN BY KB	DATE Oct. / 2023	DWG. NO. Sheet 2 of 3	REV.
--------------	---------------------	--------------------------	----------



5 7978 North Fraser Way
 Burnaby, B.C. V5J 0C7
 Tel: 604 433 4243
 Fax: 604 433 4148
 E-mail: info@maxammetal.com

VAN-MET® MODEL FSD
 TWO HOUR FIRE-RATED ACCESS DOOR
 Uninsulated Security Door for Wall Application

OPTIONS: * - DENOTES ADDITIONAL COST.

MATERIAL :-

- STANDARD MATERIAL - GALVANNEALED STEEL. SEE SHEET 1 OF 3.
- * - OPTIONAL MATERIAL - 304 STAINLESS STEEL WITH A NO. 4 POLISHED FINISH ON THE EXTERIOR SURFACE.
- * - MASONRY ANCHORS ATTACHED.

HARDWARE :-

- STANDARD HARDWARE - 1 1/8" MORTISE PREP c/w MORTISE CYLINDER. SEE SHEET 1 OF 3.
- OPTIONAL HARDWARE .
- * - CONTINUOUS PIANO HINGE.
- * - MOUNTING BRACKETS FOR ANTI-TAMPER SWITCH(ES).

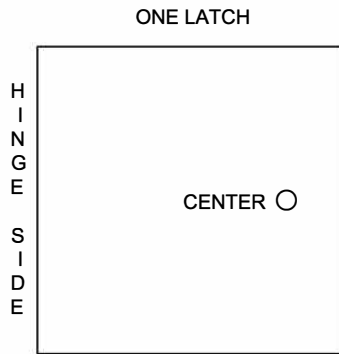

CENTER LATCH

- 1 1/8" MORTISE PREP ONLY.

PROJECT: _____

PURCHASE ORDER: _____

CONTRACTOR: _____

APPROVED BY: _____

ARCH. OR ENG.: _____

DATE: _____

Revised 26/07/22

DWN BY KB	DATE Oct / 2023	DWG. NO. Sheet 3 of 3	REV.
--------------	--------------------	--------------------------	----------