

# Drywall Accessories

Section: 09260

## ULTRA-CORNER

Product Number	Dimensions/Descriptions	Pieces Per Box
211	Ultra-thin (1/16" - 2 mm), flexible corner for use on smooth flat walls.	100

10' (3 m) Lengths

### Application:

ULTRA-CORNER, a thin - 1/16" (2 mm) - flexible profile, for use in cathedral ceilings or walls where off angle corners meet. Can be angled to any degree. Simply attach with adhesive or drywall mud.

### Specification:

ULTRA-CORNER shall be Plastic Components, Inc. #211. All drywall accessories shall conform to ASTM standards D3678 and C1047. All products shall be third party tested to meet ASTM standard D4216 and be Canadian Code Compliant. Finish compatible with drywall mud and all paint finishes. They shall be used where specified by the architect and installed per industry standards.



Patented

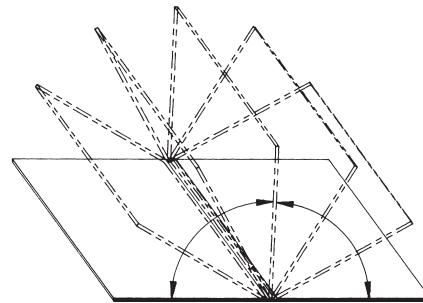

## Half Round 3/4" Bullnose

Product Number	Dimensions/Descriptions	Pieces Per Box
207	3/4" (19 mm) half round bullnose.	50
207-58		50

10' (3 m) Lengths

### Application:

Used for termination when a window or door casing trim is eliminated. Can also be used where extra layers of drywall are being used for decorative purposes. Trim is to be installed after installation of board.

### Specification:

Half Round Bullnose shall be Plastic Components, Inc. #\_\_\_\_\_. All drywall accessories shall conform to ASTM standards D3678 and C1047. All products shall be third party tested to meet ASTM standard D4216 and be Canadian Code Compliant. Finish compatible with drywall mud and all paint finishes. They shall be used where specified by the architect and installed per industry standards.

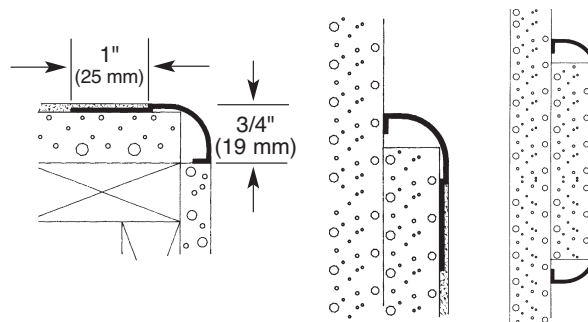

**PLASTIC PC**<sup>TM</sup>  
**COMPONENTS** inc.

C-7