



FLOOR ACCESS PANEL
Model KAFA
 Recessed 1/8" Smooth Aluminum
 For All Types of Construction

DATE



SPECIFICATIONS

GENERAL SCOPE:

Access doors shall be Karp Type KAFA as manufactured by Karp Associates, Inc., Melville, N.Y. Sizes shall be as indicated on the drawings.

CONSTRUCTION:

1. Panels shall be 1/4" 6061-T651 aluminum with the following options: recessed 1/8", flush smooth plate, flush-diamond plate.
2. Frame shall be 6063-T5 extruded aluminum with die cast corner connectors and shall be installed with rubber cork strip seal.
3. Panel shall be secured with 10-24 x 3/4 stainless steel FHMS screws.

STANDARD SIZES

A DOOR OPENING H X W (IN.)	B PANEL SIZE (IN.)	C FRAME SIZE H X W (IN.)	SHIP WT. (LBS.)
12 x 12	13 1/2 x 13 1/2	14 x 14	11.0
18 x 18	16 1/2 x 19 1/2	20 x 20	19.0
24 x 24	25 1/2 x 25 1/2	26 x 26	29.0
30 x 30	31 1/2 x 31 1/2	32 x 32	53.0
36 x 36	37 1/2 x 37 1/2	38 x 38	75.0

PROJECT DATA				
Project Name:				
Architect:				
Contractor:				
Agent/Customer Name:				
Tagging Instructions:				
Special Instructions:				
PROJECT SCHEDULE				
Qty.	H	W	Finish	Remarks

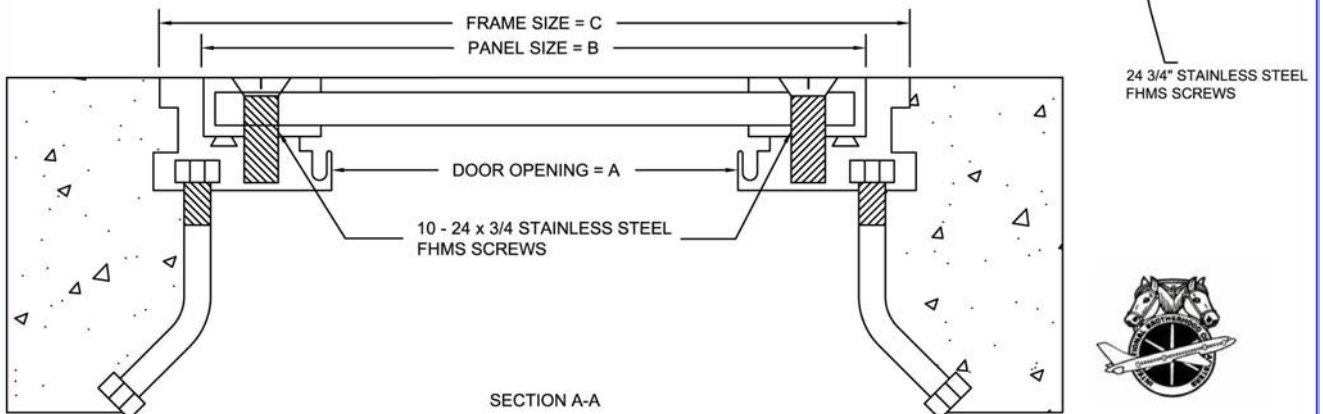
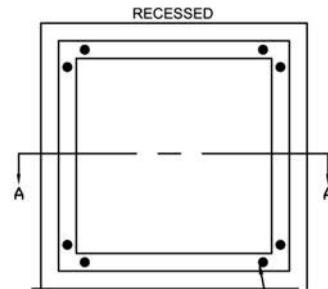

Made with Union Labor