



RECESSED ACCESS DOOR Model DSC-210 For Acoustical Tile

DATE



SPECIFICATIONS

GENERAL SCOPE:

Access doors shall be Karp Type DSC-210 as manufactured by Karp Associates, Inc., Melville, N.Y. Sizes shall be as indicated on the drawings.

CONSTRUCTION:

1. Frame shall be 14 gage steel and door shall 16 gage steel.
2. Door shall be recessed 1".
3. Hinge shall be concealed pivoting rod type.
4. Locks shall be flush and screwdriver operated with cam and studs, or shall be key operated cylinder lock with automatic dust shutter.
5. Finish shall be prime coat of rust inhibitive electrostatic powder, baked white enamel.

STANDARD SIZES

DOOR SIZE H X W (IN.)	WALL/CEILING OPENING (IN.)	NUMBER OF STUD LATCHES	SHIP WT. (LBS.)
12 x 12	12 1/8 x 12 1/8	1	6.7
18 x 18	18 1/8 x 18 1/8	2	12.4
24 x 12	24 1/8 x 12 1/8	2	10.6
24 x 24	24 1/8 x 24 1/8	2	19.2
36 x 24	36 1/8 x 24 1/8	2	32.0

PROJECT DATA
Project Name:
Architect:
Contractor:
Agent/Customer Name:
Tagging Instructions:
Special Instructions:

PROJECT SCHEDULE					
Qty.	H	W	No. of Latches	Finish	Remarks

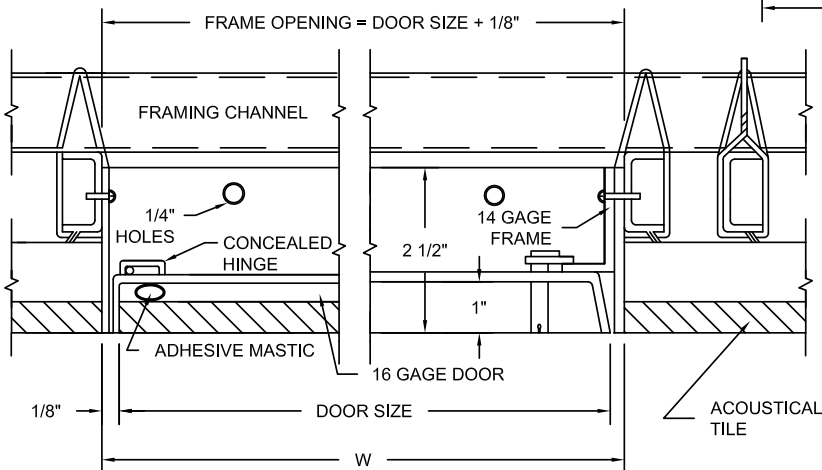
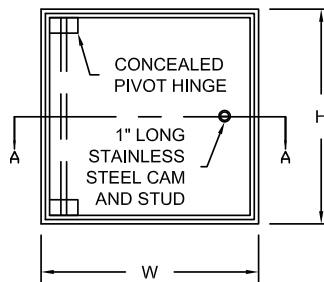

Made with Union Labor