



INSULATED EXTERIOR ACCESS DOOR

Model MX-PL (New Model)

For All Types of Construction



KARP ASSOCIATES, INC.

DATE

SPECIFICATIONS

GENERAL SCOPE:

Access doors shall be Karp Type MX-PL as manufactured by Karp Associates, Inc., Melville, N.Y. Sizes shall be as indicated on the drawings.

CONSTRUCTION:

1. Frame shall be 18 gauge galvanized steel.
2. Door shall be 18 gauge galvanized steel.
3. Door shall be welded, watertight pan.
4. Frame shall be surrounded by 22 gauge expansion casing bead with metal lath.
5. Gasketing between door and frame 3/8" wide by 1/8" thick closed cell neoprene gasketing.
6. Insulation shall be 1" thick polystyrene w/ 5.0 R-value @ 75 degree F temperature.
7. Hinge shall be continuous galvanized piano hinge.
8. Latches shall be Lift & Turn Compression Latch including cup sealing gasket finished in textured chrome. Keyed.
9. Finish shall be prime coat of rust inhibitive electrostatic powder, baked white enamel.

STANDARD SIZES (Special sizes on request)

| DOOR SIZE H X W (IN.) | WALL/CEILING OPENING (IN.) | NUMBER OF STUD LATCHES | SHIP WT. (LBS.) |
|--------------------------|-------------------------------|------------------------------|--------------------|
| 12 x 12 | 12 3/8 x 12 3/8 | 1 | 6.3 |
| 18 x 18 | 18 3/8 x 18 3/8 | 1 | 10.5 |
| 24 x 24 | 24 3/8 x 24 3/8 | 2 | 16.0 |
| 30 x 22 | 30 3/8 x 22 3/8 | 2 | 18.0 |
| 30 x 30 | 30 3/8 x 30 3/8 | 2 | 27.0 |
| 36 x 24 | 36 3/8 x 24 3/8 | 2 | 24.0 |
| 36 x 36 | 36 3/8 x 36 3/8 | 2 | 36.0 |

*Available in stainless steel

| PROJECT DATA | | | | | |
|-----------------------|---|---|----------------|--------|---------|
| Project Name: | | | | | |
| Architect: | | | | | |
| Contractor: | | | | | |
| Agent/Customer Name: | | | | | |
| Tagging Instructions: | | | | | |
| Special Instructions: | | | | | |
| PROJECT SCHEDULE | | | | | |
| Qty. | H | W | No. of Latches | Finish | Remarks |
| | | | | | |
| | | | | | |
| | | | | | |
| | | | | | |
| | | | | | |

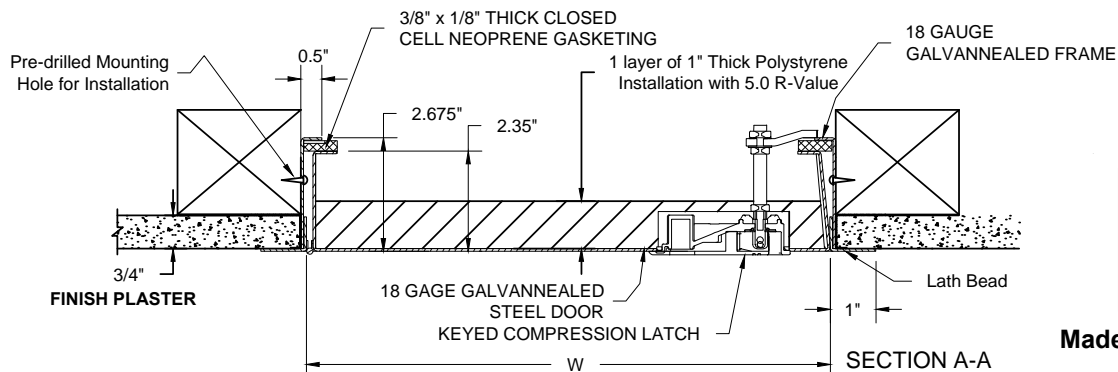
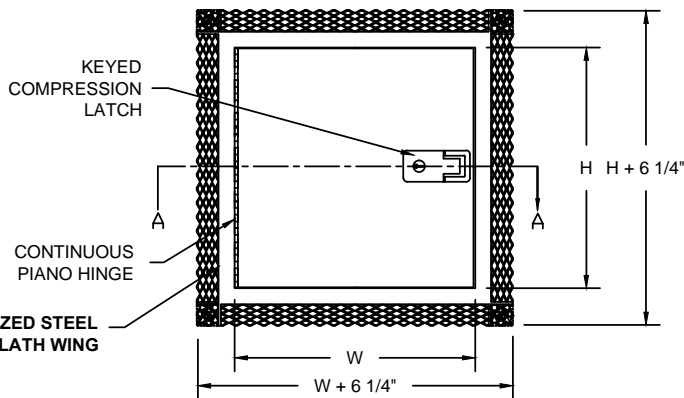

Made with Union Labor